

D38999/22 Dummy Storage Receptacle Threaded Coupling



MATING CONNECTOR
MIL-DTL-38999 Series III

Basic Part No.
D38999/22 - B W

Class Per Spec.
(Finish is Cadmium Olive Drab over Electroless Nickel)

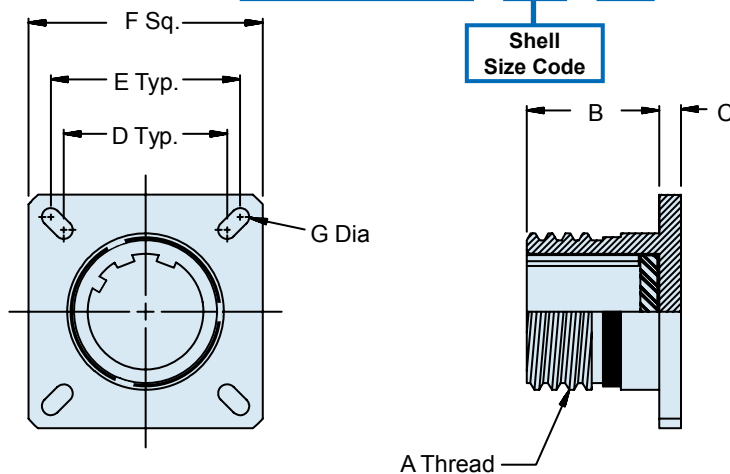

TABLE I: Shell Size Code and Dimensions

Shell Size Code	Shell Size Ref.	A Thread	B -0.0		C		D	
			Max	+0.012	(0.3)			
A (See Note 4)	9	.625-.1P-3LTS	.820	(20.83)	.098	(2.5)	.594	(15.09)
AA (See Note 5)	9	.625-.1P-3LTS	.820	(20.83)	.098	(2.5)	.594	(15.09)
B	11	.750-.1P-3LTS	.820	(20.83)	.098	(2.5)	.719	(18.26)
C	13	.875-.1P-3LTS	.820	(20.83)	.098	(2.5)	.812	(20.62)
D	15	1.000-.1P-3LTS	.820	(20.83)	.098	(2.5)	.906	(23.01)
E	17	1.187-.1P-3LTS	.820	(20.83)	.098	(2.5)	.969	(24.61)
F	19	1.250-.1P-3LTS	.820	(20.83)	.098	(2.5)	1.062	(26.97)
G	21	1.375-.1P-3LTS	.790	(20.07)	.126	(3.2)	1.156	(29.36)
H	23	1.500-.1P-3LTS	.790	(20.07)	.126	(3.2)	1.250	(31.75)
J	25	1.625-.1P-3LTS	.790	(20.07)	.126	(3.2)	1.375	(34.93)

TABLE I: Shell Size Code and Dimensions

Shell Size Code	Shell Size Ref.	E		F -0.0		Ø G	
		+0.012	(0.3)	+0.008	(0.2)		
A	9	.719	(18.26)	.937	(23.8)	.128	(3.25)
B	11	.812	(20.62)	1.031	(26.2)	.128	(3.25)
C	13	.906	(23.01)	1.126	(28.6)	.128	(3.25)
D	15	.969	(24.61)	1.220	(31.0)	.128	(3.25)
E	17	1.062	(26.97)	1.311	(33.3)	.128	(3.25)
F	19	1.156	(29.36)	1.437	(36.5)	.128	(3.25)
G	21	1.250	(31.75)	1.563	(39.7)	.128	(3.25)
H	23	1.375	(34.93)	1.689	(42.9)	.154	(3.91)
J	25	1.500	(38.10)	1.811	(46.0)	.154	(3.91)

- APPLICATION NOTES**
1. Assembly to be identified with manufacturer's name and part number, space permitting.
 2. For complete dimensions, see the applicable Military Specification.
 3. Metric dimensions (mm) are in parentheses.
 4. Shell size code "A" is for polarization C, E and N only.
 5. Shell size code "AA" is for polarization A, B and D only.